

Polymeric Nanofibers and Nanofiber Webs: A New Class Of Nonwovens

By Timothy Grafe*, Kristine Graham, Donaldson Co., Inc., PO Box 1299, Minneapolis, MN 55440 USA

Abstract

Nanofiber is a broad phrase generally referring to a fiber with a diameter less than 1 micron. While glass fibers have existed in the sub-micron range for some time and polymeric meltblown fibers are just beginning to break the micron barrier, 0.25 micron diameter electrospun nanofibers have been manufactured and used commercially for air filtration applications for more than twenty years. Several value-added nonwoven applications, including filtration, barrier fabrics, wipes, personal care, medical and pharmaceutical applications may benefit from the interesting technical properties of commercially available nanofibers and nanofiber webs.

This paper will discuss the electrospinning process for making nanofibers and nonwoven nanofiber webs from synthetic fiber-forming polymers. The resulting physical characteristics of the nanofiber webs will be discussed. In order to provide a useful context for the nonwovens industry, nanofiber webs will be compared to both meltblown and spunbond nonwovens. The description and comparison of the properties should provide product designers in the nonwovens industry with the tools to generate product and applications ideas about new uses for nanofibers.

Key Words

Nanofiber, Nanofibers, Electrospin, Electrospun, Microfiber, Sub-micron, Nylon, Electrostatic, Electrospinning

* Mail to: grafe@mail.donaldson.com; 952-887-3928; Fax 952-887-3937

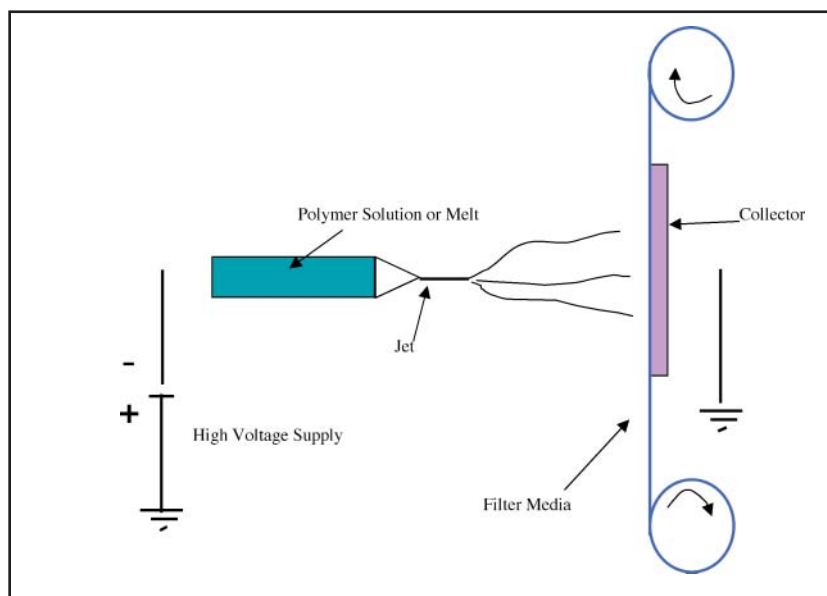

Figure 1
SCHEMATIC OF THE ELECTROSPINNING SETUP

1. Electrospinning Process For Production of Nanofibers

Polymeric nanofibers can be made using the electrospinning process, which has been described in the literature [1,2] and in patents [3]. A basic electrospinning apparatus is shown in *Figure 1*.

Electrospinning uses an electric field to draw a polymer melt or polymer solution from the tip of a capillary to a collector. A voltage is applied to the polymer, which causes a jet of the solution to be drawn toward a grounded collector. The fine jets dry to form polymeric fibers, which can be collected on a web. The electrospinning process has been documented using a variety of polymers [4, 5]. By choosing a suitable

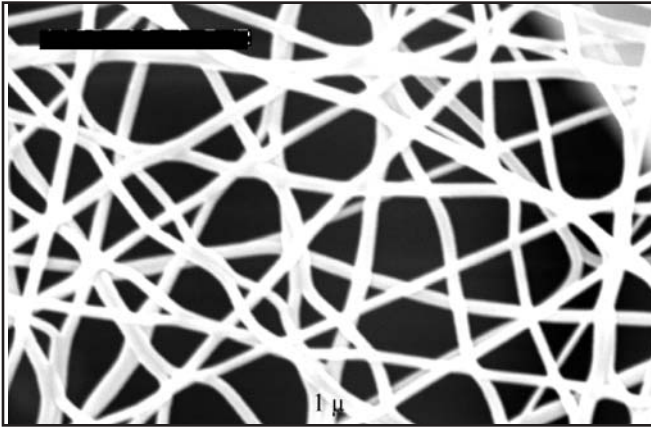

Figure 2
COMMERCIALY AVAILABLE
ELECTROSPUN NANOFIBERS

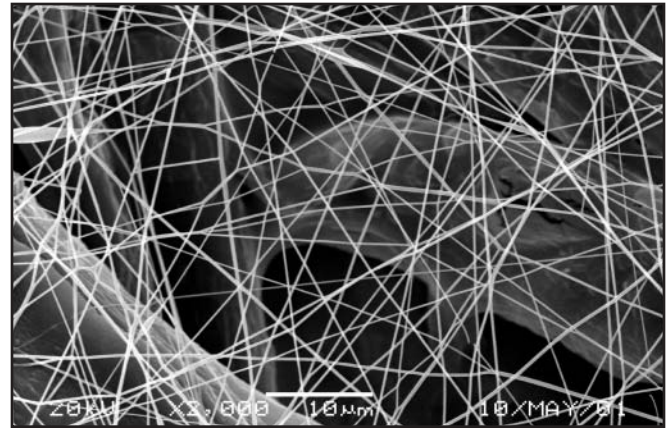

Figure 4
NANOFIBERS ON A WETLAID CELLULOSE
SUBSTRATE FOR AIR FILTRATION

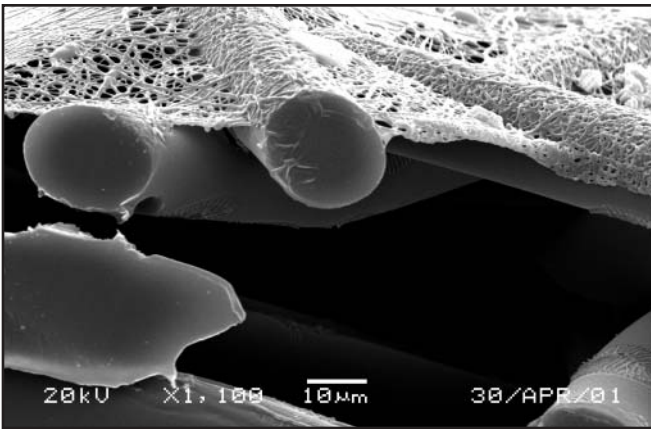

Figure 3
CROSS SECTION VIEW OF NANOFIBER WEB
ON SPUNBOND SUBSTRATE

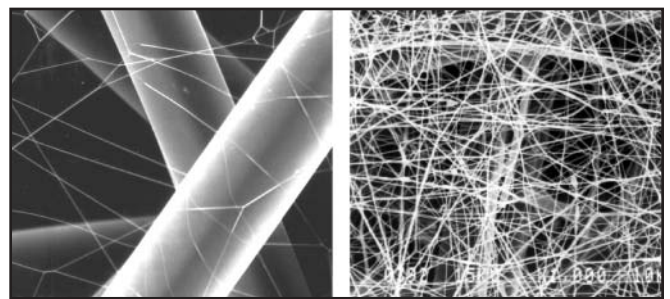

Figure 5
VARIOUS NANOFIBER WEB DENSITIES ARE
POSSIBLE THROUGH PROCESS CONTROL

polymer and solvent system, nanofibers with diameters in the range of 40-2000 nm (0.04 – 2 microns) can be made. Fiber diameters can be varied and controlled. [6]

2. Examples of Electrospun Nanofibers

Figure 2 is a 10,000X magnification scanning electron micrograph (SEM) of electrospun nanofibers. The fibers are approximately 250 nanometers in diameter. As the fibers themselves have a small diameter, the thickness of the nanofiber web can likewise be quite small, with a thickness of four nanofiber diameters approaching only one micron. The thin web has limited mechanical properties that preclude the use of conventional web handling. As a result, nanofiber webs have been applied onto various substrates. Substrates are selected to provide appropriate mechanical properties and provide complementary functionality to the nanofiber web. In the case of nanofiber filter media, substrates have been selected for pleating, filter fabrication, durability in use, and filter cleaning.

Figure 3 is a photomicrograph showing a cross-section of nanofibers electrospun onto a polyester spunbond substrate.

The substrate is chosen to provide mechanical properties, while the nanofiber web dominates filtration performance.

Figure 4 is a photomicrograph of commercially available nanofibers electrospun onto a cellulose substrate for air filtration applications. The nanofiber diameter is approximately 250 nanometers, as compared to the cellulosic fiber structure, with diameters exceeding ten microns. This composite filter media structure has been successfully pleated on high-speed rotary pleating equipment with minimal damage to the nanofiber layer.

Controlling parameters of electrospinning allows the generation of nanofiber webs with different filtration characteristics. Different fiber sizes can be made, some as small as 40 nanometers. Fibers can be put on one side or on both sides of a substrate. Additionally, *Figure 5* shows a comparison between a light layer of nanofibers and a heavier layer of nanofibers. Nanofibers have been electrospun onto a variety of substrates, including glass, polyester, nylon, and cellulose filter media substrates.

The filtration properties of nanofibers can also be shown visually by reviewing SEMs of nanofiber media that have been exposed to contamination. *Figure 6* shows a cellulose media and a cellulose/nanofiber composite media (with nanofibers on the upstream side), both of which have been loaded to the same pressure drop (0.5" w.g.) with ISO Fine

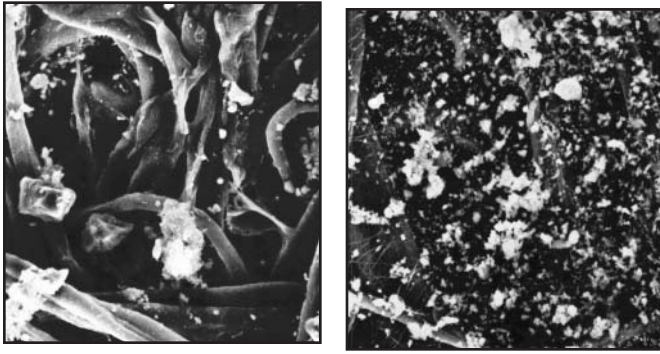

Figure 6
CELLULOSE FILTER MEDIA WITH ISO FINE TEST DUST LOADING (LEFT). NANOFIBER FILTER MEDIA WITH ISO FINE TEST DUST LOADING (RIGHT)

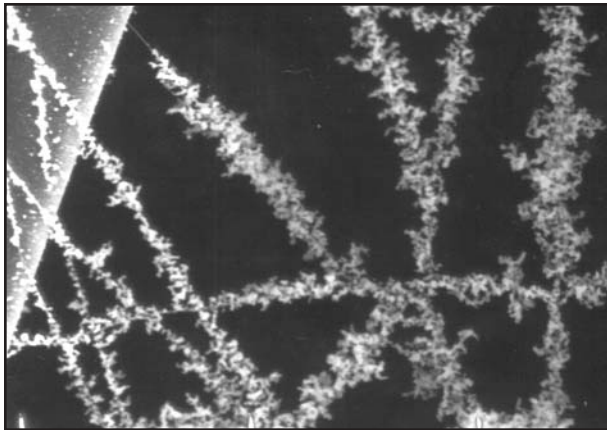

Figure 7
CAPTURE AND RETENTION OF SUB-MICRON CRYSTALS ON NANOFIBER WEB

test dust. ISO Fine test dust is commonly used for testing engine air cleaners, and contains particles in the size range of 0.7 – 70 microns. The cellulose sample shows depth loading and relatively few submicron particles, while the composite sample shows loading at the nanofiber surface and a significant quantity of submicron particles captured. The composite sample is holding 2.5 times more mass of dust than the cellulose sample [7]. The improvement in dirt holding capacity of the nanofibers is due to the small fiber diameter and correspondingly increased surface area of the fibers. These filtration benefits should similarly translate to wipes applications.

Figure 7 shows a composite media sample that has been exposed to a submicron sodium chloride contaminant, with particles in the size range of 0.01 to 0.5 microns. The nanofibers are covered with the salt particles, while the larger substrate fiber has collected relatively few of the submicron particles [8]. Increased filtration efficiency for submicron contaminants can be achieved with nanofibers. Several have suggested that using nanofibers as a carrier for functional chemistry may offer interesting benefits. By replacing the salt crystals in Figure 7 with functional materials, such as

pharmaceuticals for drug delivery applications, or antimicrobial chemistry for wipes and clothing applications, new uses for nanofiber webs as a high surface area functional chemistry delivery structures can be imagined.

3. Physical Characteristics of Commercial Nanofiber Webs: Comparison To Meltblown and Spunbonded Webs

It is useful to compare electrospun nanofiber webs to other nonwoven processes that directly produce fibrous web structures. While there are many processes to make nonwoven web materials, it is most useful to compare electrospun webs to two other important products in the nonwovens industry: meltblown and spunbonded webs. Indeed, the three processes and resulting products share two notable characteristics: (a) the process begins with a liquid phase polymer and makes fibers and webs directly in a one-step process; (b) the resulting products consist essentially of polymeric fibers with no other binders, resins or additives. Many other processes exist to make fibrous nonwovens, but generally the fibers are made independently of the web. Additionally, other nonwovens processes generally employ a chemical (such as the resin binders used in wetlaying) or a subsequent mechanical process step (such as carding or hydroentangling) to secure the fibers within the web to each other.

The simplest comparison between electrospun nanofibers, meltblown fibers and spunbonded fibers is fiber size (Table 1). The difference in fiber size leads to vast differences in basic web properties such as fiber surface area (Table 2), basis weights (Table 3), thicknesses, permeability, and strength. While the calculations of nanofiber web physical properties are often straightforward from fiber counts and fiber diameters in SEMs, the results, when expressed in the conventional units of the nonwovens industry, illustrate that electrospun nanofiber webs are categorically distinct from other nonwovens. Electrospun nanofibers have diameters that are 1 to 2 orders of magnitude smaller than meltblown fibers. This leads to a corresponding increase in fiber surface area and decrease in basis weight. While not discussed in detail here, the diameters of electrospun fibers allow the creation of webs with substantially more and smaller micropores than meltblown and spunbond webs.

A photomicrograph of a commercially available composite spunbond – meltblown – spunbond structure (Figure 8) conveniently shows the relative fiber sizes of spunbond and meltblown fibers compared to the nanofiber structures previously shown [9]. Like nanofibers, meltblown fibers typically need a supporting structure and are generally employed in a composite structure.

4. Commercial Production of Nanofiber Webs For New Nonwovens Applications

While the electrospinning process for nanofiber production has been known for a long time, the rate of academic research and publications has only recently increased. The academic

Table 1
COMPARISON OF FIBER DIAMETERS FROM VARIOUS FIBER/NONWOVEN WEB PROCESSES

Fiber Type	Fiber Size Range, microns	Fiber Size Range, denier
Electrospun Nanofibers	0.04 – 2	0.00002 – 0.06
Meltblown Fibers	2 – 10	0.03 - 1
Spunbond Fibers	15 - 40	1.5 - 12

Denier Calculation based on fiber specific gravity = 1. Specific gravity values of common fiber polymers range from 0.92 (PP) to 1.14 (PA66) to 1.38 (PET)

Table 2
FIBER SURFACE AREA PER MASS OF FIBER MATERIAL FOR VARIOUS FIBER SIZES

Fiber Type	Fiber Size, microns	Fiber Surface Area per mass of fiber material, m ² /g
Electrospun Nanofiber	0.05	80
Electrospun Nanofiber	0.2	20
Small Meltblown Fiber	2.0	2
Spunbond Fiber	20	0.2

Specific Surface area calculations based on fiber specific gravity = 1.

Table 3
BASIS WEIGHTS OF NONWOVENS FROM VARIOUS PROCESSES

	Basis Weight Range (oz/yd ²)	Basis Weight Range (g/m ²)
Electrospun Nanofiber Web	0.0005 – 0.015	0.02 – 0.5
Meltblown Fiber Web	0.15 – 6	5 - 200
Spunbond Fiber Web	0.3 – 10	8 – 350

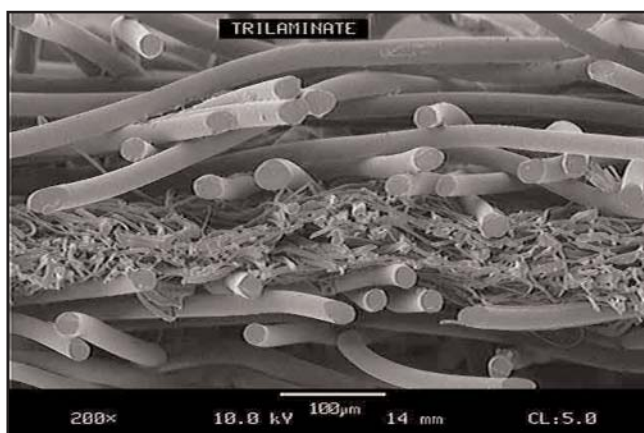

Figure 8
SPUNBOND – MELTBLOWN – SPUNBOND COMPOSITE NONWOVEN STRUCTURE

research of electrospun nanofibers has increased the exposure of the technology and identified several promising applications for nanofibers. However, a significant hurdle has

remained for the nonwovens industry at large: quantities of nanofiber webs from a scaled-up, commercially viable electrospinning process have not been available to explore new uses and applications.

As previously reported, nanofiber web composites have been used for several air filtration applications. Many of these air filters are made from webs of nanofiber filter media in widths exceeding 24 inches (610 mm). An example of this product is shown in *Figure 9*. A commercial facility manufacturing polyamide nanofiber web composites currently has production volumes in excess of 10,000 square meters per day.

As might be expected from the physical properties of electrospun nanofiber webs, conventional techniques (e.g., b-radiation, optical methods) to measure web properties are not practical due to the small fiber size and thin structure.

However, there has been a

need to measure the output of the process.

An on-line web filtration efficiency test method (OEM) was invented.[10] The test system uses two conventional laser particle counters with the addition of a specialized sampling head. The sampling head incorporates an air curtain effect to allow efficiency measurements at speeds up to several hundred feet per minute. This method gathers data about web consistency in both the machine and cross directions. This test method has been applied to product development, manufacturing process development, and production process control. Several other novel techniques have been developed to measure the output and control the quality of a commercial electrospinning process.*

While nanofibers and nanofiber webs offer exciting new properties for the nonwovens industry, like all technologies,

* Luzhansky, D.M. "Quality Control in Manufacturing of Electrospun Nanofiber, Composites" presented at The Fiber Society Fall Technical Meeting, October, 2002, Natick, MA, USA



Figure 9
COMMERCIAL AIR FILTRATION CARTRIDGE
USING NANOFIBER FILTER MEDIA

they have limitations. Nanofiber webs cannot be handled on normal web handling equipment without additional support. As a result, nanofiber webs must be used in a composite structure, with some other nonwoven material as a support. Nanofiber webs are very thin. This is an inherent limitation if the web is meant to hold or absorb significant volumes of solids and/or liquids.

Conclusion

The availability of commercial quantities of nanofiber web products, along with methods and equipment to characterize and control the process output, should accelerate the incorporation of nanofibers into new products. The low basis weight, small fiber diameter and pore size, high surface area and choice of fiber chemistry are important tools in the development of new products such as barrier fabrics, cleaning wipes, personal care wipes, and medical and pharmaceutical products such as wound dressings and tissue scaffolds.

Acknowledgements

The authors gratefully acknowledge the work of Mike O'Brien and Suzan Nunnink on the SEM. Portions of this work were previously published [11, 12].

References

1. Doshi, J., and Reneker, D. H., "Electrospinning Process and Applications of Electrospun Fibers", *Journal of Electrostatics*, Volume 35, 1995, pp. 151-160.

2. Tsai, P.P., Schreuder-Gibson, H., Gibson, P. "Different electrostatic methods for making electret filters", *Journal of Electrostatics*, Volume 54, 2002.

3. Formhals, A., "Process and Apparatus for Preparing Artificial Threads", U.S. Patent 1,975,504, October 2, 1934.

4. Chun, I., Reneker, D. H., Fong, H., Fang, X., Deitzel, J., Beck Tan, N., Kearns, K., "Carbon Nanofibers from Polyacrylonitrile and Mesophase Pitch", *Journal of Advanced Materials*, Volume 31, Number 1, January 1999, pages 36 – 41.

5. Reneker, D. H., and Chun, I., "Nanometre Diameter Fibres of Polymer, Produced by Electrospinning", *Nanotechnology*, Volume 7, 1996, pages 216-233.

6. Kalayci, V.E., "Electrostatic Solution Spinning", MS Thesis, University of Massachusetts, Dartmouth, July, 2002

7. Schaefer, J.W., and Olson, L.M., "Air Filtration Media for Transportation Applications", *Filtration & Separation*, March 1998.

8. Schaefer, J.W., McDonald, B., and Gogins, M., "Nanofibers in Aerosol Filtration", Nanotechnology for the Soldier System Conference, sponsored by the U.S. Army Soldier Systems Command (SSCOM), Army Research Office (ARO), Army Research Laboratory (ARL), and the National Science Foundation (NSF), Cambridge, MA, July 1998.

9. <http://www.bbafiltration.com/UltraFlo-1.html>

10. Gogins, Mark A. U.S. Patent 5,203,201 assigned to Donaldson Company Inc.

11. Grafe, T.H., Gogins, M., Barris, M.A., Schaefer, J., Canepa, R., "Nanofibers in Filtration Applications in Transportation"; *Filtration 2001 Conference Proceedings*, 2001.

12. Graham, K., Ouyang, M., Raether, T., Grafe, T., McDonald, B., Knauf, P., "Polymeric Nanofibers in Air Filtration Applications"; *American Filtration & Separations Society Proceedings*, April 2002.

— INJ

TAPPI

people resources solutions™

